

Parkstone

A Product of Hardscapes USA™



The Parkstone paver creates a pleasant woven design that complements most residential and business structures. It lends a sense of order that can simplify a busy setting. Parkstone works well in a variety of situations, but

tends to provide just the right touch for larger driveways, pool decks, and patios. It is a paver that looks good surrounded by concrete curbing or lush, green landscaping.



HARDSCAPES USA

Parkstone

A Product of Hardscapes USA™

Parkstone	60mm
Sq. ft. per cube	102
Pieces per cube	360
Weight per cube (approx).....	2856 lbs

Dimensions:

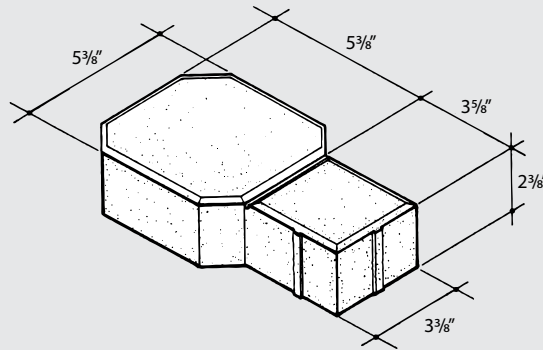

Patterns:

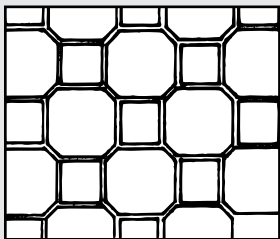

Color Selections:

Standard colors are available using both gray and white cements. **Gray Cement:** Terra Cotta, Charcoal, Buff, Dark Brown, Chestnut, Light Brown, St. Joe, O3-Orange, Red, Gray, Medium Gray, Dark Green*. **White Cement:** Sandstone, Maize, Seacrest Yellow, Light Almond, Dark Almond, Bone, Peach, Pink, Salisbury, White, Light Green*. An extensive collection of two and three color blends is available. Call **1-800-239-7421** for details.

Typical Installation:

1. Excavate subgrade material and compact the area which has been cleared. Then backfill with dense-graded aggregate (typically 4 to 6 inches for light vehicular and pedestrian traffic, increasing to 8 to 12 inches for heavy vehicular and industrial use) as directed by site engineer, architect, or landscape architect.
2. Place bedding course of sharp, normal-weight screening sand to a uniform depth of approximately 1-1/2 inches leveled to grade.
3. Install Hardscapes USA pavers on bedding course in pattern desired.
4. Where required, cut paving stones with an approved cutter to fit accurately, neatly and without damaged edges.
5. Tamp paving stones with mechanical vibrator uniformly level, true to grade and free of movement.
6. Fill voids in joints by sweeping in a fine, dry masonry sand.

* Both Dark Green and Light Green colors are special order only.

The information contained herein is accurate to the best of our knowledge, but Hardscapes USA assumes no liability whatsoever for its accuracy or completeness. Final determination of suitability of any material is the sole responsibility of the user.



HARDSCAPES USA



Product Composition:

Hardscapes USA pavers are made with zero-slump concrete, which is then hydraulically pressed while being subjected to extremely high frequency vibrations. This process results in Hardscapes USA pavers having a compressive strength of 8,000 psi or greater (ASTM C-936) and a moisture absorption of less than 5%.

About Hardscapes USA

Hardscapes USA is a manufacturer and distributor of a wide range of quality concrete products including pavers, retaining wall units, and patio products. They are produced and distributed throughout the Southeast and are used in residential, commercial, and industrial construction.

Hardscapes USA pavers are synonymous with distinctive paving applications and have earned a reputation for both quality and durability. Hardscapes USA pavers are well-suited for both the discriminating design application and the heavy-duty, functional project.